

DATASHEET AND OPERATING GUIDE

PTC5000/PTC10000

PCB-Mount Temperature Controllers



FEATURES AND BENEFITS

- Drive ± 5 or ± 10 A of TEC or heater current
- Single supply operation: 5 to 30 VDC
- Small package: 2.32" x 2.15" x 3.85"
- Remote Output Enable and Temperature Setpoint controls
- Short term stability of 0.0012°C (off-ambient)
- Long term stability 0.002°C
- Selectable sensor bias current
- Adjustable current limit
- PI Control with "Smart Integrator"
- Failsafe Setpoint default in case of remote temperature setpoint signal error

TIME-TESTED RELIABILITY

The PTC Series PCB-Mount Temperature Controllers are based on our long-proven PTC-CH linear controllers, and deliver the precision performance and reliability you expect from Wavelength Electronics.

PTC Series controllers are found in such diverse applications as particle and droplet measurement, communications, manufacturing test, and medical systems.

POWERFUL AND EASY TO USE

The PTC controllers operate from a single power supply between 5 V and 30 V, and two models drive ± 5 A or ± 10 A to a Peltier thermoelectric cooler or a resistive heater. These controllers mount directly to your circuit board.

PTC controllers interface with a variety of temperature sensors, and the bias current is adjustable in order to maximize controller sensitivity and stability for your application.

You can use the PTCEVAL board to quickly configure the PTC controller for prototyping. Using the same controller for development and production helps guarantee there are no surprises when it's time to integrate the final design.

CONTENTS

	PAGE
QUICK CONNECT GUIDE	2
PIN DESCRIPTIONS	3
ELECTRICAL SPECIFICATIONS	4
SAFETY INFORMATION	5
OPERATING INSTRUCTIONS	6
OPERATING WITH THE PTCEVAL BOARD	10
ADDITIONAL TECHNICAL INFORMATION	11
TROUBLESHOOTING	13
MECHANICAL SPECIFICATIONS	15
PTCEVAL EVAL BOARD DIMENSIONS & SCHEMATIC	16
CERTIFICATION AND WARRANTY	17

ORDERING INFORMATION

PART NO	DESCRIPTION
PTC5000	± 5 A Temperature Controller
PTC10000	± 10 A Temperature Controller
PTCEVAL	Evaluation board for PTC-PCB Series Controllers



QUICK CONNECT GUIDE



TO ENSURE SAFE OPERATION OF THE PTC CONTROLLER, IT IS IMPERATIVE THAT YOU DETERMINE THAT THE UNIT WILL BE OPERATING WITHIN THE INTERNAL HEAT DISSIPATION SAFE OPERATING AREA (SOA).

Go to the Wavelength Electronics website for the most accurate, up-to-date, and easy to use SOA calculator:

<http://www.teamwavelength.com/support/calculator/soa/soatc.php>

If the power supply voltage is above 5 VDC it is critical to verify that the PTC will be operating within the Safe Operating Area before proceeding with setup and configuration.

Figure 1 is the Quick Connect schematic for TEC operation using a Negative Temperature Coefficient sensor; this is the most common mode of operation for the PTC controllers.

Additional wiring diagrams are found in **Wire the PTC Temperature Controller on page 8**.

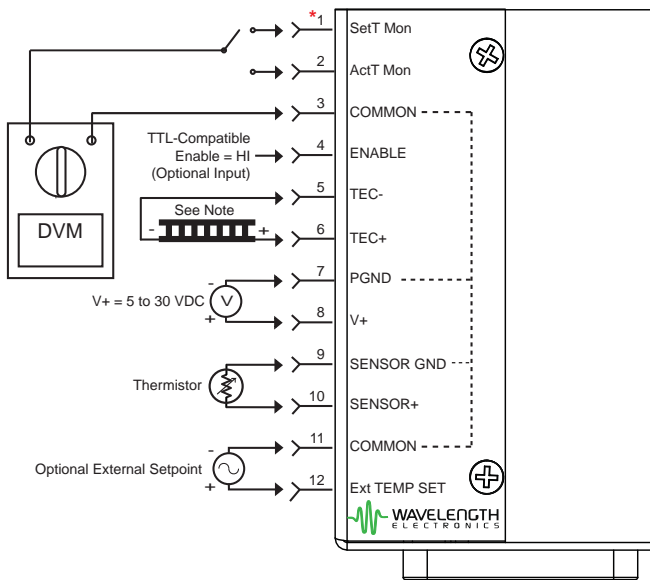

Note: Current flows from TEC+ to TEC-. Connect the TEC+ lead to pin 6, and the TEC- lead to pin 5. Keep the wires as short as possible to reduce the voltage drop at high current.

Use caution when the PTC is combined with a PLD laser driver: if the TEC or thermistor is connected to the laser diode, two power supplies are required and must float independently of each other.

*** Pin 1 is the pin farthest from the fan.**

Figure 1. Basic Wiring Diagram, TEC Operation

Figure 2 is a top view of the PTC, illustrating the onboard switches and trim pots. Additional information is found in **Preconfiguration on page 7**.

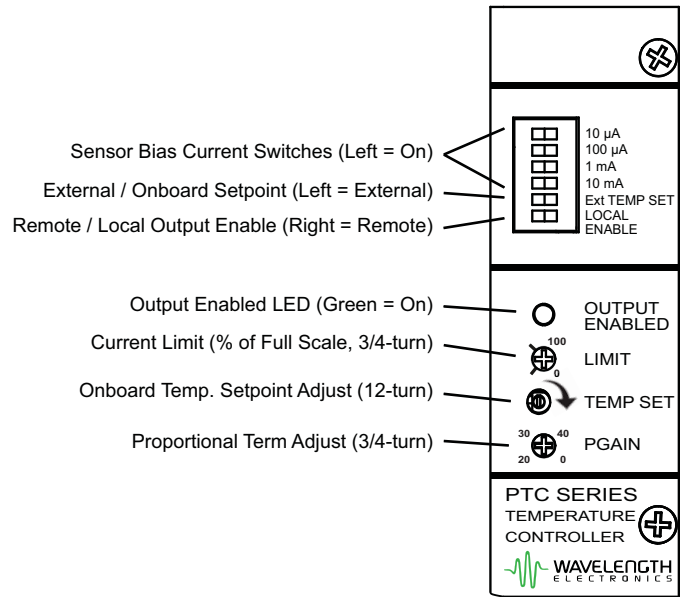

Figure 2. PTC Top View

For setup and configuration, we recommend using a test load in place of the TEC or resistive heater, connected directly to pins 5 and 6 on the controller. Recommended test loads:

- For PTC5000, MP9100-1.00-1%. This resistor must be attached to a heatsink.
- For PTC10000, MP9100-0.50-1%. This resistor must be attached to a heatsink.

We also recommend using a test circuit to simulate a thermistor. **Figure 3** shows a simple adjustable test circuit.

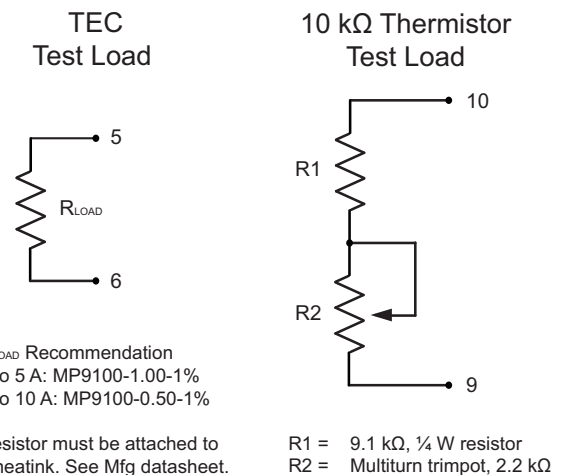

Figure 3. TEC Test Load & Thermistor Simulator Test Circuit

PIN DESCRIPTIONS

Table 1. Pin Descriptions

PIN	NAME	DESCRIPTION
1	SetT MON	Temperature setpoint voltage monitor. Refer to the Electrical Specifications for the voltage range. Impedance 1 k Ω .
2	ActT MON	Actual temperature sensor voltage monitor. Range 0 to 6 V. When the temperature is stabilized at the setpoint the ActT MON voltage will match the voltage at pin 1 (SetT MON). Impedance 1 k Ω .
3	COMMON	Common reference ground for low-current signals. Used with the monitor outputs (pins 1 & 2) and the ENABLE input (pin 4). Do not use for high current return.
4	ENABLE	Remote Enable. Can be controlled using a switch or TTL-compatible input signal where Disable = LO (< 1.45 V). Enable = HI (> 3.4 V). The Enable state between 1.45 V and 3.4 V is indeterminate. Max voltage range is zero to V_s . Damage threshold is 30 V.
5	TEC-	Negative side of TEC. This pin sinks the current from the TEC (when using NTC sensors).
6	TEC+	Positive side of TEC. This pin supplies the current to the TEC (when using NTC sensors). Refer to the operating instructions for proper connections to a TEC or Resistive Heater based on the type of sensor being used.
7	PGND	Power supply ground. This is the only ground connection designed as a high current return.
8	V+ or V_s	Power supply input, 5 – 30 VDC. The power supply must be rated to source at least 1.5-times the load current plus the PTC quiescent current. Reference the Safe Operating Area calculator if V_s is greater than 5 VDC.
9	SENSOR GND	Ground connection for the temperature sensor (pin 10). Refer to the Specifications table for input voltage range. Do not use for high current return.
10	SENSOR+	Positive side of temperature sensor. Bias current is driven from SENSOR+ to SENSOR GND.
11	COMMON	Reference ground for the Ext TEMP SET input signal (pin 12).
12	Ext TEMP SET	External Temperature Setpoint voltage. Used for external voltage control of the temperature setpoint. Impedance 200 k Ω . The switch on the controller top panel must be properly configured for this input to be recognized. The Ext TEMP SET voltage does not sum with the onboard trimpot setting. Damage threshold 7.2 V. If the signal falls below 0.3 V the setpoint will default to 1 V (contact factory for alternate default settings). To reset the default safety circuit, the Ext TEMP SET voltage must be > 0.4 V.

Table 2. Control and Monitor Transfer Functions

FUNCTION	TRANSFER FUNCTION	DESCRIPTION
Ext TEMP SET	1 V / V	The controller will drive the TEC or heater in order to make the voltage across the temperature sensor match the Ext TEMP SET voltage.
SetT MON	1 V / V	The setpoint temperature monitor voltage matches the setpoint voltage set by the onboard trimpot or the external setpoint input to pin 12.
ActT MON	1 V / V	The actual temperature monitor voltage matches the voltage drop across the temperature sensor.

Table 3. PTCEVAL Input Voltage Protection Circuit

CONDITION	PROTECTION CIRCUIT ACTIVATION VOLTAGE	TO RESET THE PROTECTION CIRCUIT
Undervoltage	$V_s < 4.8$ VDC	set $V_s > 5.2$ VDC
Overvoltage	$V_s > 30.4$ VDC	set $V_s < 28.8$ VDC

ELECTRICAL SPECIFICATIONS

PARAMETER	SYMBOL	PTC5000	PTC10000	UNIT	NOTE
ABSOLUTE MAXIMUM RATINGS					
Supply Voltage ¹	V_s or $V+$	5 to 30		VDC	
Internal Power Dissipation	P_{MAX}	110		W	derating begins at 25°C
Case Operating Temperature		-40 to 85		°C	
Case Storage Temperature		-65 to 125		°C	
Weight		11.3		oz	320.4 g
Size		3.85 x 2.15 x 2.32		inches	97.7 x 54.7 x 58.9 mm
OUTPUT CURRENT					
Max Output Current	I_{MAX}	±5	±10	A	$V_s > 5.2$ VDC
Output Current Limit	I_{LIM}	Symmetrically applied to heat and cool current			
Minimum Compliance Voltage	V_{COMP}	$V_s - 1.7$	$V_s - 3$	V	$V_s > 5.2$ VDC
Maximum Compliance Voltage	V_{COMP}	28.3	27	V	
Short Term Stability, 1 hr, Off ambient ¹		< 0.0012		°C	using 10 kΩ thermistor with 100 μA bias current at 25°C.
Short Term Stability, 1 hr, On ambient ¹		< 0.0014		°C	
Long Term Stability, 24 hr, Off ambient ¹		< 0.002		°C	
Temperature Coefficient		< 100		ppm / °C	
POWER SUPPLY					
Power Supply Voltage ²	V_s or $V+$	5 to 30		VDC	
Quiescent Current		220		mA	
Minimum Current Rating		1.1 * (I_{TEC} + Quiescent Current)		A	
TEMPERATURE SENSORS					
Sensor Compatibility		Thermistor, RTD, IC Sensors			
Sensor Input Voltage Range		0 to ($V_s - 1.5$) 0 to 5.5		V	$V_s < 7$ VDC $V_s = 7$ to 30 VDC
Sensor Input Damage Threshold		5.5		V	
BIAS CURRENT					
Bias Current Selection		10 μA, 100μA, 1 mA, 10 mA			
Bias Current Accuracy		±0.2%	±0.5%		over full temperature range
Bias Current Temperature Coefficient		25 10		ppm / °C	$V_s < 7.5$ VDC $V_s > 7.5$ VDC
EXTERNAL SETPOINT AND MONITORS					
External Setpoint Voltage Range (Ext TEMP SET)		0 to 5 0 to 6.2		V	$V_s < 7$ VDC $V_s = 7$ to 30 VDC
External Setpoint Damage Threshold		< -0.5 or > 7.2		V	
SetT MON Output Voltage Range		0 to 6.2		V	$V_s = 7$ to 30 VDC
ActT MON Output Voltage Range		0 to 6		V	$V_s = 7$ to 30 VDC
Sensor Voltage to Act T MON Accuracy		1		mV	
Set T MON to Act T MON Accuracy		1		mV	
FEEDBACK LOOP					
Proportional Gain Range		5 to 40		A / V	
Integrator Time Constant		1.5	1.8	A / V-s	can be changed at factory

¹ When using resistive heaters, stability can only be consistently achieved when specified temperatures are 10°C or more above ambient.

² The PTCEVAL is equipped with over-, under-, and reverse-voltage protection.

SAFETY INFORMATION

SAFE OPERATING AREA – DO NOT EXCEED INTERNAL POWER DISSIPATION LIMITS

Before attempting to operate the PTC, it is imperative that you first determine that the unit will operate within the *Safe Operating Area (SOA)*. Operating the unit outside of the SOA may damage the controller or the load. Operating outside of the SOA will void the warranty.

Go to the Wavelength Electronics website for the most accurate, up-to-date, and easy to use SOA calculator:

<http://www.teamwavelength.com/support/calculator/soa/soatc.php>



TO ENSURE SAFE OPERATION OF THE PTC CONTROLLER, IT IS IMPERATIVE THAT YOU DETERMINE IF THE UNIT IS GOING TO BE OPERATING WITHIN THE INTERNAL HEAT DISSIPATION SAFE OPERATING AREA (SOA).

THEORY OF OPERATION

The PTC5000 and PTC10000 are high-current linear temperature controllers that deliver bidirectional current to Peltier Effect thermoelectric coolers, or unidirectional current to resistive heaters.

The fundamental operating principle is that the controller adjusts the TEC drive current in order to change the temperature of the sensor that is connected to the thermal load. The goal is to make the voltage across the sensor match the setpoint voltage, and then keep them equal in spite of changes to ambient conditions and variations in thermal load.

The controller measures the load temperature by driving a current through the temperature sensor and measuring the voltage drop across it. It may be useful to remember that you do not directly adjust the setpoint temperature. Rather, you adjust a *voltage signal* that represents the sensor voltage at the desired temperature setpoint.

While the output is enabled the controller continuously compares the setpoint voltage and the actual sensor voltage. If there is a difference between the two signals the controller adjusts the output current—thereby driving the TEC or heater to change temperature—until the difference is zero.

Once the actual sensor voltage equals the setpoint voltage, the controller makes minor adjustments to the output current in order to keep the difference at zero. If the ambient temperature changes, for example, the controller will adjust the drive current accordingly.

The controller includes features that help protect the load from damage, and also make it more versatile in a wide array of applications. These features are explained in detail in **Operating Instructions on page 6**.

- **Current limit:** the adjustable current limit must be set correctly in order to avoid over-driving and damaging the TEC or heater.
- **External and Onboard temperature setpoint control:** for prototyping and benchtop applications the temperature setpoint can be adjusted with the onboard trimpot. When the controller is integrated into an automated control system, the temperature setpoint can be adjusted by external voltage signal.
- **Remote Enable and Local Enable:** the controller can be configured to use a remote signal to enable the output, or it can be configured so that the output is always on whenever power is applied to the unit.
- **Control loop:** the controller employs a smart Proportional-Integrating control loop to adjust the drive current. The proportional term is user-adjustable, and when properly configured will quickly settle the load to temperature with minimal overshoot and ringing.

OPERATING INSTRUCTIONS

The PTC requires minimal external electronics. If you are using the module on the benchtop or for prototyping your control system, we recommend the PTCEVAL board.

This chapter is divided into two sections:

- The Preconfiguration section
 - » Onboard Adjustments and Controls
 - » Set the Sensor Bias Current
 - » Choose External vs. Onboard Setpoint
 - » Choose Remote vs. Local Enable
 - » Calculate the Temperature Setpoint Voltage
 - » Understand the Proportional Gain Term
 - » Wire the PTC Temperature Controller
- Instructions to operate the PTC with the PTCEVAL evaluation board.

NECESSARY EQUIPMENT

The following equipment is the minimum necessary to configure the PTC for basic operation:

- PTC controller, PTCEVAL evaluation board (recommended)
- Digital multimeter, 4-½ digit resolution recommended
- Power supply, 5 – 30 VDC, current rated for at least 1.5-times the TEC current plus PTC quiescent current. Connect via the terminal strip on the PTCEVAL, or can be terminated with 2.5 mm two-conductor plug such as Wavelength part PWRPAK-5V.
- Thermistor or other temperature sensor
- Peltier-type thermoelectric module, or resistive heater
- Heatsink for the temperature-controlled load, mounting hardware, thermal washers or paste
- Connecting wires

SAFE OPERATING AREA AND THERMAL DESIGN CONSIDERATIONS

To determine if the PTC controller is suitable for your application and if it will be operating in the safe range, consult the instructions for calculating the Safe Operating Area online at

<http://www.teamwavelength.com/support/calculator/soa/soatc.php>

If you have any questions about the Safe Operating Area calculator, call the factory for free and prompt technical assistance.



IT IS IMPERATIVE THAT YOU VERIFY THE UNIT WILL OPERATE WITHIN THE INTERNAL HEAT DISSIPATION SAFE OPERATING AREA (SOA).

OPERATING THE CONTROLLER OUTSIDE THE SOA MAY DAMAGE OR DESTROY THE PTC AND/OR LOAD.

When you assemble and mount the TEC (or heater), heatsink, and temperature sensor, make sure the physical connections between the components are solid. We recommend using thermal paste or thermal washers at the load/TEC and TEC/heatsink interfaces. The thermistor must be in firm contact with the load in order to achieve stable and reliable temperature control.

PREVENT DAMAGE FROM ELECTROSTATIC DISCHARGE

Before proceeding, it is critical that you take precautions to prevent electrostatic discharge (ESD) damage to the driver and your load. ESD damage can result from improper handling of sensitive electronics, and is easily preventable with simple precautions. Reference this website for information on ESD best-practices:

http://eed.gsfc.nasa.gov/562/ESD_BestPractices.htm

We recommend that you always observe ESD precautions when handling the PTC controller.

PRECONFIGURATION

ONBOARD ADJUSTMENTS AND CONTROLS

Onboard controls are accessed on the top panel of the PTC and must be set according to the operation mode. The controls are illustrated in **Figure 4**.

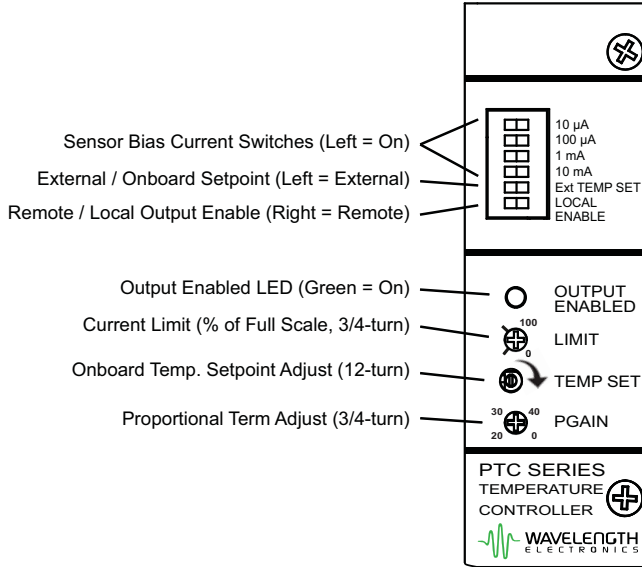

Figure 4. PTC Top View

SET THE SENSOR BIAS CURRENT

Choosing the right thermistor resistance range and bias current is important to optimize performance of your temperature control system. **Table 4** shows the resistance at 25°C of six thermistors that are available from Wavelength Electronics.

Four DIP switches are used to set the bias current driven to the temperature sensor.

- Set the sensor bias current by sliding the appropriate switch to the left (ON) position. All other bias current switches must remain in the right (OFF) position.
- For AD590 temperature sensors, all sensor bias switches must remain in the right (OFF) position.
- If you are using a 10 kΩ thermistor, set the 100 µA switch to the left (ON) and leave the others to the right (OFF).
- If multiple switches are ON, the bias currents are additive.

Table 4. Temperature Ranges of Common Thermistors

THERMISTOR MODEL NO.	R @ 25°C	10 µA	100 µA
TCS605	5 kΩ	-55 to 2°C	-20 to 33°C
TCS610, TCS10K5	10 kΩ	-45 to 13°C	-8 to 50°C
TCS620	20 kΩ	-35 to 28°C	6 to 69°C
TCS650	50 kΩ	-18 to 49°C	25 to 92°C
TCS651	100 kΩ	-6 to 67°C	41 to 114°C

CHOOSE EXTERNAL VS. ONBOARD SETPOINT

The PTC includes a 12-turn trimpot for onboard temperature setpoint control, or you can use an external signal.

- **External Setpoint.** Set the Ext TEMP SET switch on the top of the unit to the left (EXTERNAL).
- **Onboard Setpoint.** Set the Ext TEMP SET switch on the top of the unit to the right (ONBOARD).

CHOOSE REMOTE VS. LOCAL ENABLE

The PTC output can be enabled either remotely or set to an always-on state. Set the unit for Remote Enable during setup and configuration.

- **Remote Enable**
 - » Set the LOCAL ENABLE switch on the top of the unit to the right (REMOTE).
 - » To enable the output, apply a TTL-High signal to pin 4 (High = 3.4 V or greater). To disable the output, the signal on pin 4 must be less than 1.45 V.
- **Local Enable**
 - » Set the LOCAL ENABLE switch to the left (LOCAL).
 - » Be advised that the output current will be enabled at all times while there is power to the unit.

CALCULATE THE TEMPERATURE SETPOINT VOLTAGE

The actual temperature in degrees is not set directly on the PTC unit. Instead, the temperature is controlled by a voltage signal equal to the voltage drop across the sensor at the desired temperature setpoint. Calculate the temperature setpoint voltage as follows:

- Refer to the resistance vs. temperature table for your thermistor or RTD and find the resistance at the desired temperature. If you are using an AD590 or LM335, refer to the datasheet for the temperature transfer function.
- Calculate the sensor voltage drop at the desired setpoint temperature. This is the setpoint voltage value on SetT MON:

» Thermistor and RTD:

$$V_{\text{SETPOINT}} = I_{\text{BIAS}} * R_{\text{THERMISTOR}}$$

» LM335 and AD590:

$$V_{\text{SETPOINT}} = 2.730 + (0.010 * T_{\text{SETPOINT}})$$

UNDERSTAND THE PROPORTIONAL GAIN TERM

The gain value is factory-set to a common starting place that is suitable for a wide range of thermal loads. Once the controller is operating under normal conditions, the gain term can be tuned for faster settling with minimal overshoot and ringing.

Refer to [TN-TC01 - Optimizing Thermoelectric Temperature Control Systems](#) for details about setting the proportional gain term.

WIRE THE PTC TEMPERATURE CONTROLLER

Refer to **Table 5** to determine which configuration applies to your application, and then reference the associated figure for wiring instructions.

Refer to **Table 1. Pin Descriptions on page 3** for complete information on the pin functions and operating parameters.

Refer to **Figure 3** for load and thermistor test circuit recommendations.

Table 5. Wiring Configurations

CONFIGURATION	DIAGRAM
TEC with Negative Temperature Coefficient (NTC) Sensor	Figure 5
Heater with Negative Temperature Coefficient (NTC) Sensor	Figure 6
Heater with Positive Temperature Coefficient (PTC) Sensor	Figure 7
TEC with Positive Temperature Coefficient (PTC) Sensor (AD590, LM335, RTD)	Figure 8

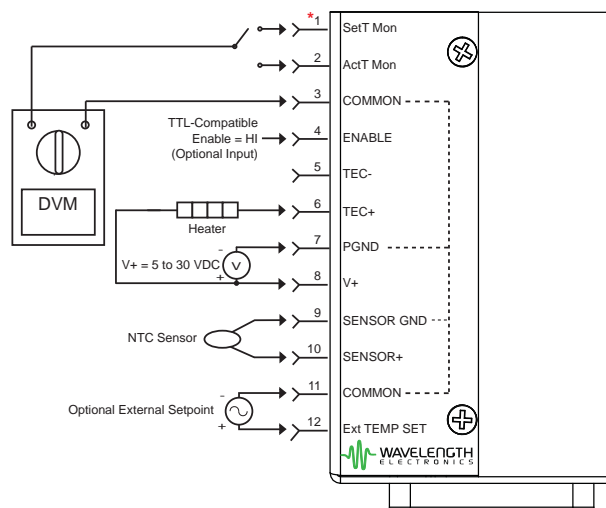

Keep the wires to the heater as short as possible to reduce the voltage drop at high current.

Use caution when the PTC is combined with a PLD laser driver: if the heater or thermistor is connected to the laser diode, two power supplies are required and must float independently of each other.

*** Pin 1 is the pin farthest from the fan.**

Figure 6. Wiring Diagram for Heater and Negative Temperature Coefficient Sensor

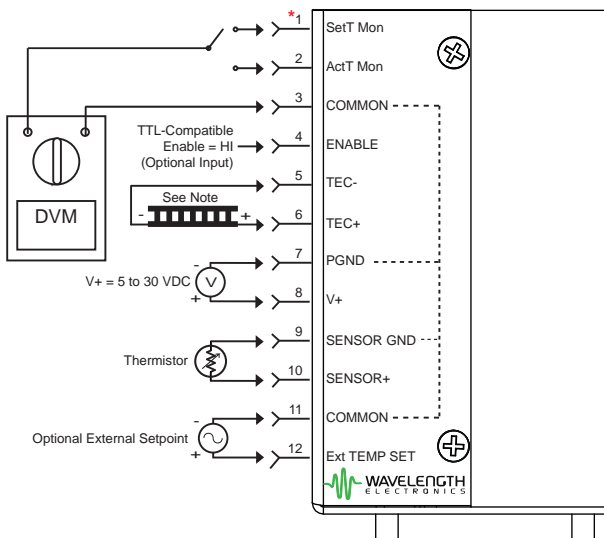

Note: Current flows from TEC+ to TEC-. Connect the TEC+ lead to pin 6, and the TEC- lead to pin 5. Keep the wires as short as possible to reduce the voltage drop at high current.

Use caution when the PTC is combined with a PLD laser driver: if the TEC or thermistor is connected to the laser diode, two power supplies are required and must float independently of each other.

*** Pin 1 is the pin farthest from the fan.**

Figure 5. Wiring Diagram for TEC Operating with Negative Temperature Coefficient Sensor

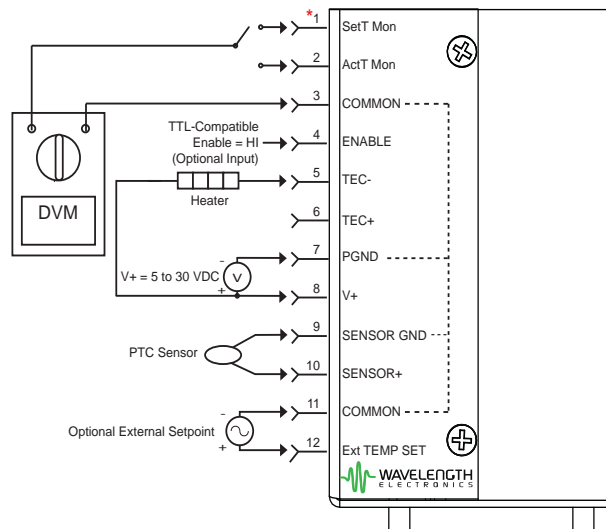

Keep the wires to the heater as short as possible to reduce the voltage drop at high current.

Use caution when the PTC is combined with a PLD laser driver: if the heater or thermistor is connected to the laser diode, two power supplies are required and must float independently of each other.

*** Pin 1 is the pin farthest from the fan.**

Figure 7. Wiring Diagram for Heater and Positive Temperature Coefficient Sensor

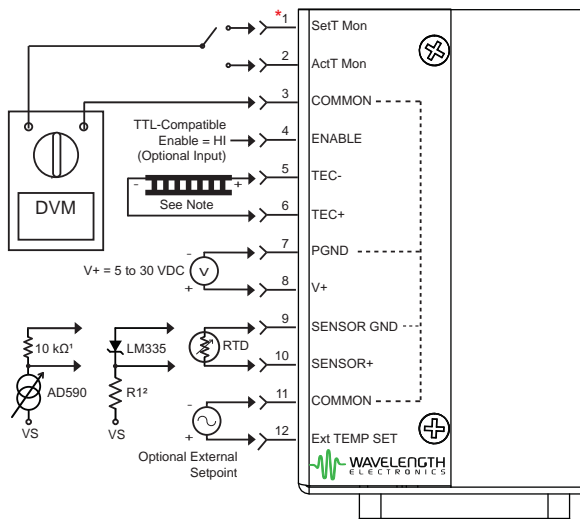

1. Omit the 10 kΩ resistor and leave pin 9 open if using the AD590 with the PTCEVAL board. Refer to the AD590 datasheet for operating requirements.

2. Refer to the LM335 datasheet to determine the value of R1.

3. Current flows from TEC+ to TEC-. For PTC sensors, connect the TEC+ lead to pin 5, and the TEC- lead to pin 6. Keep the wires as short as possible to reduce the voltage drop at high current.

Use caution when the PTC is combined with a PLD laser driver: if the TEC or thermistor is connected to the laser diode, two power supplies are required and must float independently of each other.

*** Pin 1 is the pin farthest from the fan.**

Figure 8. TEC with Positive Temperature Coefficient Sensor (AD590, LM335 or RTD)

OPERATING WITH THE PTCEVAL BOARD

Reference **Figure 9** for switch and control locations on the PTCEVAL board, and configure the evaluation board as follows:

- Set the POWER switch to OFF
- Set the OUTPUT switch to DISABLE
- Set the MONITOR switch to SET T
- If you are using an AD590 sensor, set the sensor jumper to cover the right two pins. The jumper places a 10 k Ω resistor in the circuit (see **Figure 18** for the PTCEVAL schematic). For all other temperature sensors, leave the jumper covering the left two pins.

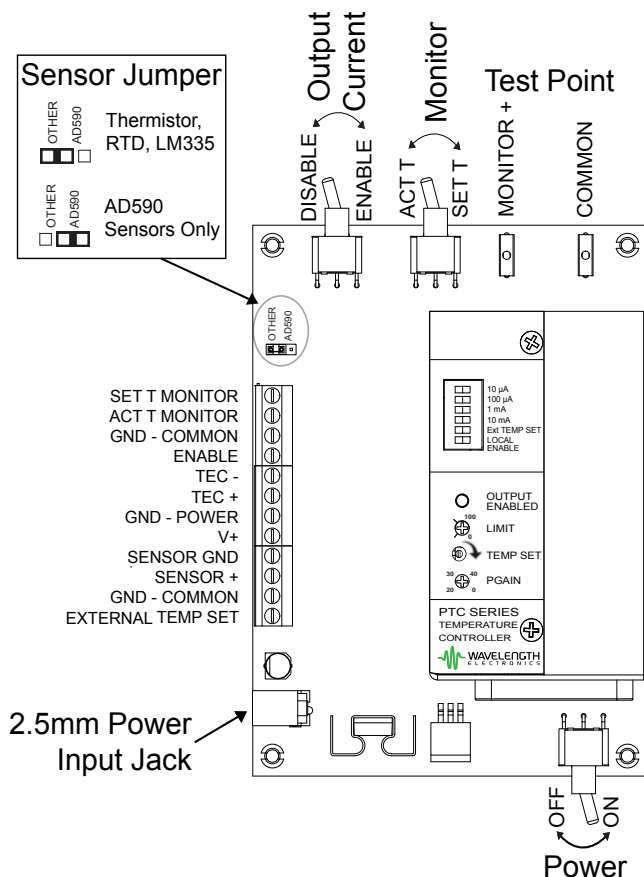

Figure 9. PTCEVAL Top View

On the PTC unit set the following parameters:

- Set the LOCAL ENABLE switch to the right (REMOTE)
- Turn the current limit trimpot to zero (fully counter-clockwise) and then clockwise to set the limit current as a percentage of full-scale output. The limit current should be set at or below the value recommended by the TEC manufacturer. The limit can be more precisely set by monitoring a voltage test point on the circuit board; refer to **Setting the Current Limit More Accurately on page 11**.

Place the PTC unit on the evaluation board. Hold the PTC in place and turn the evaluation board over. Insert the two screws through the small holes in the printed circuit board and tighten.

Solder the PTC pins to the PTCEVAL board.

Switch on the power supply; set the evaluation board POWER switch to ON.

Set the setpoint temperature voltage with the onboard trimpot:

- Connect a voltmeter across the MONITOR and COMMON test points on the upper right edge of board. The test point sockets accept a standard 2 mm multimeter probe tip.
- Adjust the TEMP SET trimpot on the PTC unit until the displayed voltage matches the setpoint voltage calculated above. Turn the trimpot to the right to increase the setpoint voltage, left to decrease.
- The temperature can also be set externally by applying a signal to pin 12. Refer to **External Temperature Setpoint Input on page 11**.

Set the Monitor switch to ACT T to monitor the actual sensor voltage on the multimeter.

Enable the output using the switch on the evaluation board. The OUTPUT ENABLED LED on the PTC will illuminate green when the output is on.

The voltage displayed on the DVM should begin to approach temperature setpoint voltage. If the actual sensor voltage is not approaching the sensor setpoint voltage, disable the output and reference **Troubleshooting on page 13**.

Once you understand how the controller works in your system, adjust the gain term to optimize temperature settling performance.

Once proper operation is verified, disable the output and set the POWER switch to OFF.

PTCEVAL INPUT VOLTAGE PROTECTION

The PTCEVAL board is equipped with a circuit to protect the PTC unit from over-, under-, and reverse-voltage conditions. Refer to **Table 3** for details on the protection circuit activation and reset voltage levels.

ADDITIONAL TECHNICAL INFORMATION

This section includes useful technical information on these topics:

- Setting the Current Limit More Accurately
- Remotely Setting the Current Limit
- “External Temperature Setpoint Input”
- “Product Variations”
- Safe Operating Area Calculation

SETTING THE CURRENT LIMIT MORE ACCURATELY

The current limit can be more accurately set using a voltmeter to monitor an internal test point while the trimpot is adjusted. The test point is accessible from the open end of the unit, and is a small hoop of metal soldered to the circuit board. **Figure 10** shows the location of the internal test point.

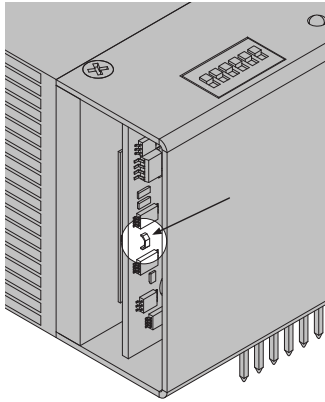

Figure 10. Internal Test Point

Connect the positive lead of a voltmeter to the test point; we recommend the clamping-type voltmeter probe. Connect the negative probe to COMMON (pin 3).

Switch on power to the PTC, and enable the output.

Calculate the voltage that corresponds to the required current limit.

The transfer function is 0.2 V / A for the PTC5000 and 0.1 V / A for the PTC10000.

$$V_{\text{LIMIT}} = I_{\text{LIMIT}} * \text{Transfer Function}$$

Adjust the LIMIT trimpot on the top of the PTC until the voltmeter displays the desired V_{LIMIT} value.

REMOTEY SETTING THE CURRENT LIMIT

The current limit can be set remotely by wiring to an internal via and applying a voltage signal. We recommend that this feature is used only when necessary, and only by experienced electronics users.

Contact the factory for information on how to configure the unit to accept remote current limit signals.

EXTERNAL TEMPERATURE SETPOINT INPUT

Pin 12 of the PTC is the Ext TEMP SET input, and is used to set the temperature setpoint remotely. The input voltage range is determined by the supply voltage (see **Electrical Specifications on page 4**) and the damage threshold is 7.2 V.

The PTC must be configured to reference the Ext TEMP SET pin; refer to **Choose External vs. Onboard Setpoint on page 6**.

The signal can be directly input from a benchtop power supply, or a variable resistor divider network can be employed. **Figure 11** illustrates an example circuit.

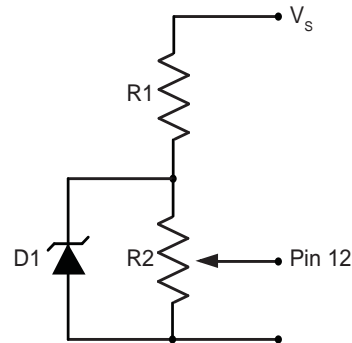

- V_s = Supply voltage (5 to 30 V)
- D1 = Bandgap reference* (LM4040)
- R1 = 2.2 k Ω , 1 W resistor
- R2 = Trimpot, 10 k Ω to 100 k Ω

* V_s must be at least 1 volt greater than the voltage value of D1.

Figure 11. Ext TEMP SET example circuit

PRODUCT VARIATIONS

We design and manufacture our products in-house, and that gives us the unique ability to modify our drivers and controllers to suit exactly your application. Our Product Variation service allows us to quickly and cost-effectively address your design requests, from prototype quantities to long-term high-volume manufacturing.

Examples of past Product Variations include:

- Replacing trimpots (current limit, setpoint, P_{GAIN}) with fixed-value resistors to maximize long-term stability in an OEM laser controller system
- Optimizing heatsink size and configuration to fit within the space constraints of your electronics chassis
- Increasing the maximum output current

SAFE OPERATING AREA CALCULATION

The Safe Operating Area of the PTC is a determined by the amount of power that can be dissipated within the output stage of the controller. If that power limit is exceeded permanent damage can result.

Refer to the Wavelength Electronics website for the most up-to-date SOA calculator for our products. The online tool is fast and easy to use, and also takes into consideration ambient operating temperature.

<http://www.teamwavelength.com/support/calculator/soa/soatc.php>



DO NOT OPERATE THE UNIT OUTSIDE THE SAFE OPERATING AREA CURVE.

OPERATING THE PTC OUTSIDE OF THE SOA VOIDS THE WARRANTY.

Follow these steps to use the SOA Chart to determine if the PTC will be operating safely. Refer to the example SOA chart in **Figure 12**. Actual SOA charts for the PTC5000 and PTC10000 are shown in **Figure 13** and **Figure 14**.

- Determine the V_S supply voltage for the PTC controller. For this example assume $V_S = 20$ VDC.
- Refer to the TEC datasheet to find the maximum voltage (V_{MAX}) and current (I_{MAX}) specifications. For this example, assume $V_{MAX} = 15$ V and $I_{MAX} = 8.5$ A.
- Calculate the voltage drop across the controller:

$$V_{DROP} = V_S - V_{MAX}$$

- Mark V_{DROP} on the X-axis, and extend a line upward
- Mark I_{MAX} on the Y-axis, and extend a line to the right until it intersects the V_{DROP} line
- On the X-axis, mark the supply voltage (V_S)
- Extend a diagonal line from V_S to the intersection of the V_{DROP} and I_{MAX} lines; this is the Load Line
- If the Load Line crosses the Safe Operating Area line at any point, the configuration is not safe.

If the SOA calculator indicates the PTC will be outside of the Safe Operating Area, the system must be changed so that the Load Line lies completely within the Safe Operating Area.

In order to shift the load line to the left, the circuit must be changed so that less power is dissipated within the controller. This is accomplished by reducing the total power dissipation of the entire circuit, or by changing the load so that it dissipates more power.

There are several ways to reconfigure the system to reduce power dissipation in the controller:

- Reduce the supply voltage (V_S)
- Increase the load impedance
- Reduce the current limit

See Wavelength Electronics Application Note [AN-LDTC01: The Principle of the Safe Operating Area](#) for information on shifting the Load Line.

After changing any of the parameters, recalculate the SOA to make sure the controller will operate safely. If you have questions, or run into difficulties calculating the SOA, contact Wavelength Electronics for assistance.

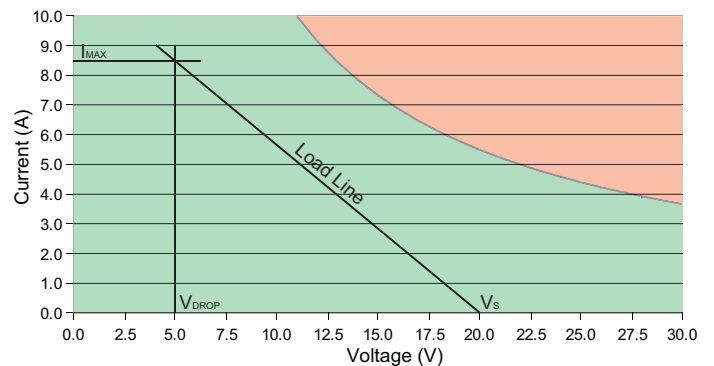

Figure 12. Example SOA Chart

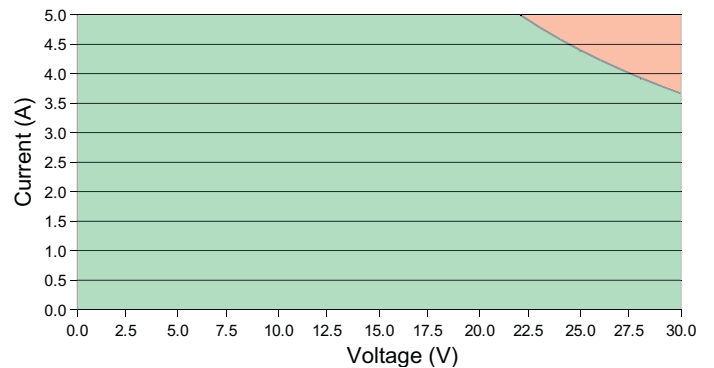

Figure 13. SOA Chart, PTC5000

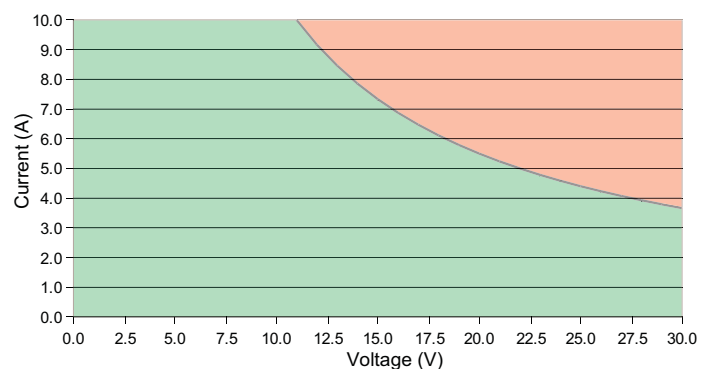

Figure 14. SOA Chart, PTC10000

TROUBLESHOOTING

PROBLEM	POTENTIAL CAUSES	SOLUTIONS
Output will not enable –OR– Output will not disable	Improperly configured REMOTE switch on the PTC unit	<ul style="list-style-type: none"> If you are using the evaluation board, make sure that the REMOTE switch on the top of the PTC unit is set to the right position. Then use the Enable/Disable switch on the evaluation board to control the output. If you are using the PTC unit stand-alone, and are not using the REMOTE ENABLE input (pin 4), then the REMOTE switch should be set to the left position. Keep in mind that in this state the output will be enabled as soon as power is applied to the PTC unit.
	Remote Enable signal is not correct	If you are using the PTC unit stand-alone and are using the REMOTE ENABLE input (pin 4), make sure that the TTL-compatible signal is correctly configured (< 1.45 V = Output Disable; > 3.4 V = Output Enable).
Temperature is decreasing when it should be increasing –OR– Temperature is increasing when it should be decreasing	The TEC may be connected backwards to the PTC	<p>The convention is that the red wire on the TEC module connects to TEC+ (pin 6) and the black wire to TEC- (pin 5). If your TEC is connected in this manner and the problem persists, the TEC module itself may be wired in reverse. Switch off power to the system, reverse the connections to the PTC, and then try again to operate the system.</p> <p>TEC wiring polarity is dependent on temperature sensor type (NTC vs. PTC). Verify that the polarity is correct for the sensor type you are using (see Table 5. Wiring Configurations on page 8).</p>
Temperature increases beyond the setpoint and will not come down	The heatsink may be inadequately sized to dissipate the heat from the load and TEC module, and now the system is in a condition called thermal runaway	<ul style="list-style-type: none"> Increase the size of the heatsink, add a fan to blow air over the heatsink, and/or reduce the ambient air temperature around the heatsink. Apply a thin layer of thermal paste or use thermal washers between the load, the TEC surfaces, and the heatsink.
	The TEC and heatsink are not adequately sized for the thermal load	The heat being generated by the load may be too great for the TEC to pump to the heatsink; a larger TEC may be needed. Consult our technical note TN-TC01 at http://www.teamwavelength.com/downloads/notes/tn-tc01.pdf
Temperature does not stabilize very well at the setpoint	Poor thermal contact between components of the thermal load	Use thermal paste or washers between the load/TEC and TEC/heatsink interfaces. Make sure the temperature sensor is in good thermal contact with the load.
	Unit is operating outside of the ideal region of the temperature sensor	The sensor type and bias current should be selected to maximize sensitivity at the target temperature. Thermistors provide the best performance, particularly for applications where a single setpoint temperature must be accurately maintained. For example, at 25°C a 10 kΩ thermistor has a sensitivity of 43 mV / °C, whereas an RTD sensor has a sensitivity of 4 mV / °C.
	Proportional control term is set too high	Reduce the value of the proportional term. For more information reference Wavelength's technical note TN-TC01 at http://www.teamwavelength.com/downloads/notes/tn-tc01.pdf

Continued

TROUBLESHOOTING, CONTINUED

PROBLEM	POTENTIAL CAUSES	SOLUTIONS
Temperature does not reach the setpoint	Insufficient current driven to the TEC or Heater	Increase the current limit - but DO NOT exceed the specifications of the TEC or heater.
	The controller does not have sufficient compliance voltage to drive the TEC or heater	Increase the power supply voltage; be certain to verify that the controller is within the Safe Operating Area; the SOA calculator is found at: http://www.teamwavelength.com/support/calculator/soa/soatc.php
PTC does not respond to external temperature setpoint input	The Ext TEMP SET switch is improperly configured	To configure the PTC to reference the setpoint signal on pin 12, set the Ext TEMP SET switch on the top of the unit to the Left.
	The EXTERNAL TEMP SET signal is below the minimum signal value of 0.3 V	If the EXT TEMP SET signal falls below 0.3 V, the PTC defaults to a "safe temperature" setpoint voltage of 1 V. The actual safe temperature depends on the sensor and bias current configuration. For a 10 kΩ thermistor at 100 μA bias current, the default temperature setpoint is 25°C. The safe temperature setpoint voltage can be changed at the factory if your application requires it.
PTCEVAL board not functioning correctly; PTCEVAL switches off	Input power supply voltage out of range	Check that the input supply voltage is between 5 VDC and 30 VDC when the PTC is operating under high current load. <ul style="list-style-type: none"> The under-voltage circuit switches off power to the PTC if the input voltage falls below 4.8 VDC. To reset the under-voltage circuit the input voltage must exceed 5.2 VDC. The over-voltage circuit switches off power to the PTC if the input voltage exceeds 30.4 VDC. To reset the over-voltage circuit the input voltage must be less than 28.8 VDC.
POWER LED on PTCEVAL blinking on and off	Faulty input power supply	Verify that the power supply is able to supply sufficient current to the PTC and is not current limited.
Temperature is slow to stabilize and is not within the specifications	Setpoint temperature is set close to the ambient temperature	Set the temperature at least 10°C above ambient when using a resistive heater. A resistive heater is unable to precisely maintain temperatures near ambient because once the temperature overshoots the setpoint, the controller turns off and relies on ambient temperature to cool the load. If setting the temperature 10°C or more above ambient is not possible, then choose a thermoelectric controller, which can alternately heat and cool the load to maintain a more precise setpoint temperature.

MECHANICAL SPECIFICATIONS

DIMENSIONS - PTC5000 / PTC10000

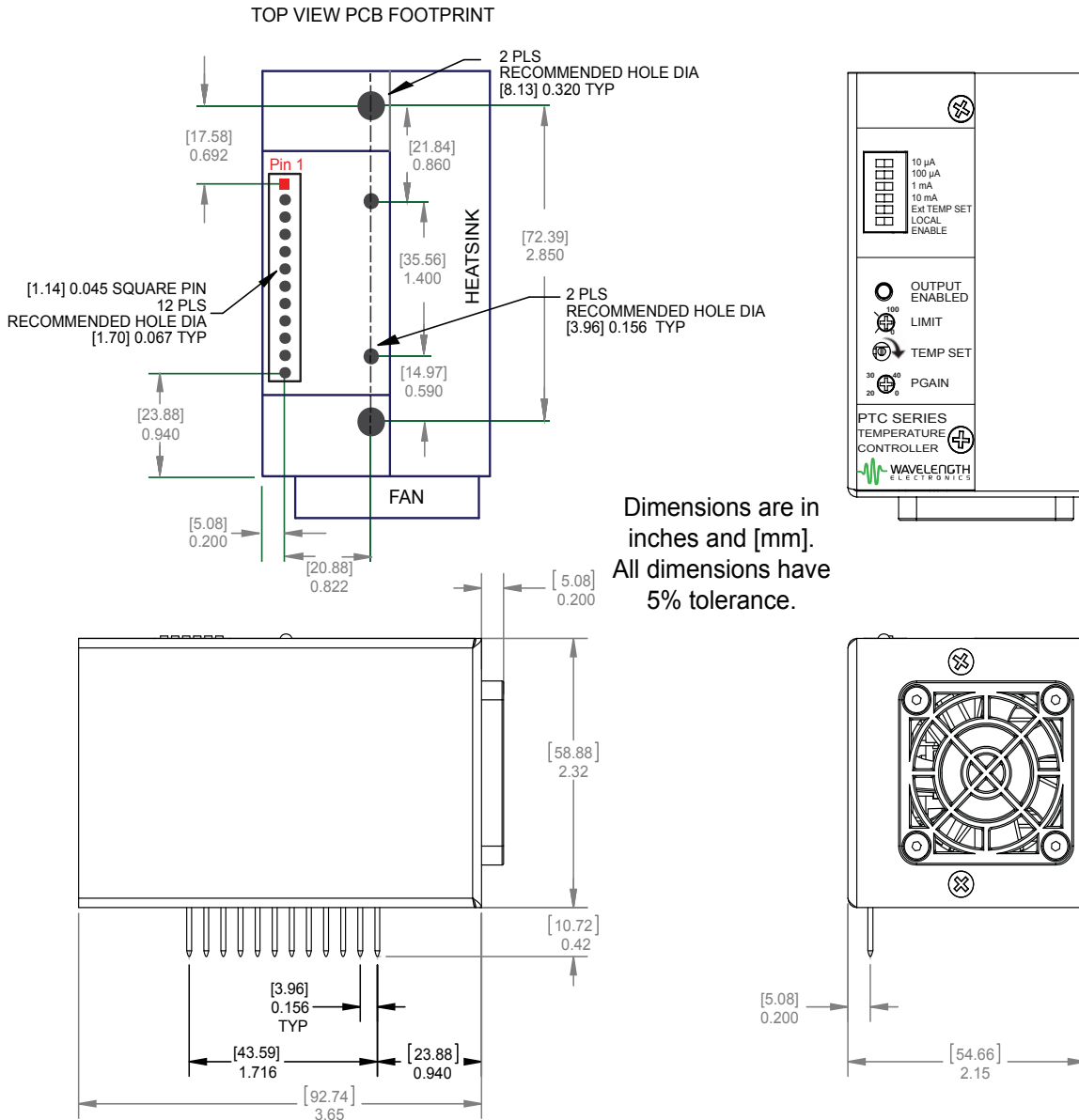

Figure 15. PTC5000 / PTC10000 Dimensions

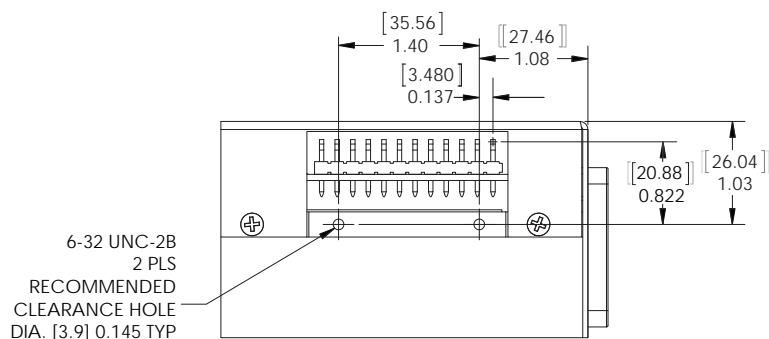
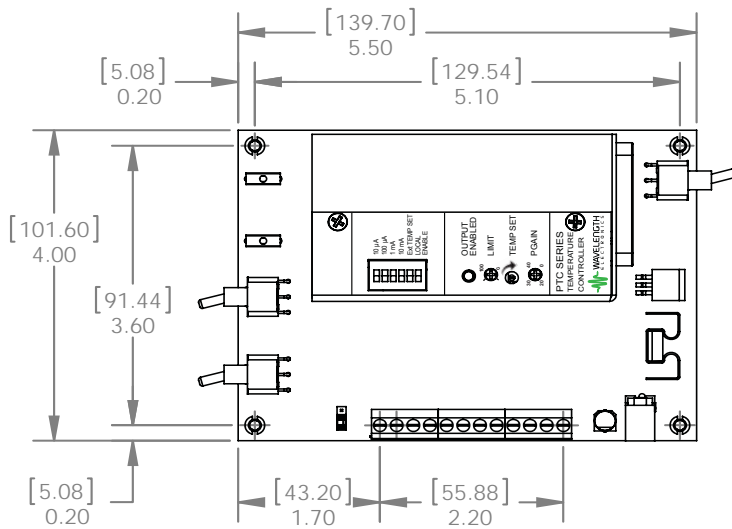

Figure 16. Bottom View, PTC Mounting Holes

PTCEVAL EVALUATION BOARD DIMENSIONS & SCHEMATIC



Dimensions are in [mm] and inches.
All dimensions have 5% tolerance.

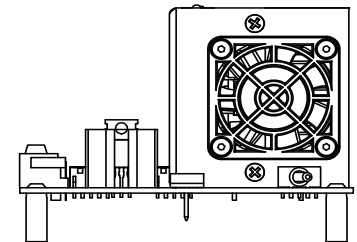
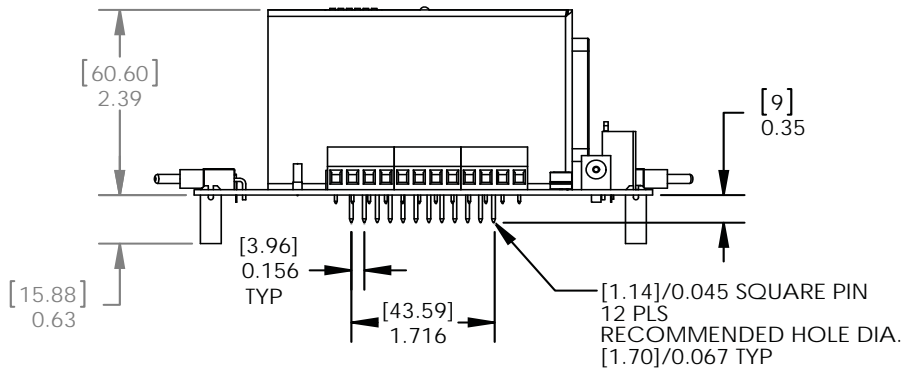
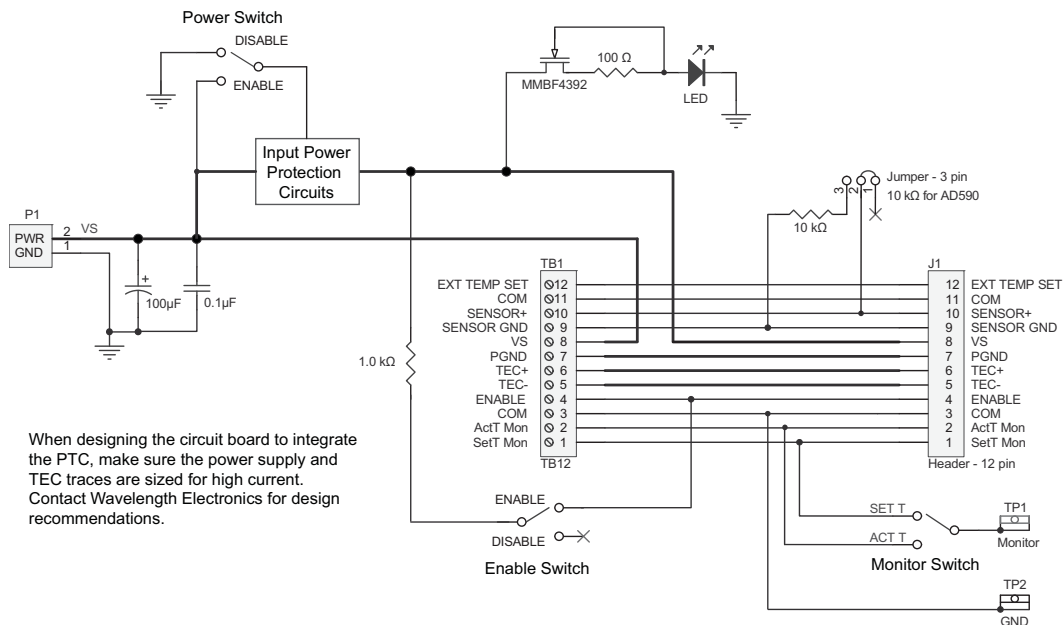

Figure 17. PTC Evaluation Board with PTC Unit Installed



When designing the circuit board to integrate the PTC, make sure the power supply and TEC traces are sized for high current. Contact Wavelength Electronics for design recommendations.

Figure 18. PTC Eval Schematic

CERTIFICATION AND WARRANTY

CERTIFICATION

Wavelength Electronics, Inc. (Wavelength) certifies that this product met its published specifications at the time of shipment. Wavelength further certifies that its calibration measurements are traceable to the United States National Institute of Standards and Technology, to the extent allowed by that organization's calibration facilities, and to the calibration facilities of other International Standards Organization members.

WARRANTY

This Wavelength product is warranted against defects in materials and workmanship for a period of one (1) year from date of shipment. During the warranty period, Wavelength will, at its option, either repair or replace products which prove to be defective.

WARRANTY SERVICE

For warranty service or repair, this product must be returned to the factory. An RMA is required for products returned to Wavelength for warranty service. The Buyer shall prepay shipping charges to Wavelength and Wavelength shall pay shipping charges to return the product to the Buyer upon determination of defective materials or workmanship. However, the Buyer shall pay all shipping charges, duties, and taxes for products returned to Wavelength from another country.

LIMITATIONS OF WARRANTY

The warranty shall not apply to defects resulting from improper use or misuse of the product or operation outside published specifications. No other warranty is expressed or implied. Wavelength specifically disclaims the implied warranties of merchantability and fitness for a particular purpose.

EXCLUSIVE REMEDIES

The remedies provided herein are the Buyer's sole and exclusive remedies. Wavelength shall not be liable for any direct, indirect, special, incidental, or consequential damages, whether based on contract, tort, or any other legal theory.

REVERSE ENGINEERING PROHIBITED

Buyer, End-User, or Third-Party Reseller are expressly prohibited from reverse engineering, decompiling, or disassembling this product.

NOTICE

The information contained in this document is subject to change without notice. Wavelength will not be liable for errors contained herein or for incidental or consequential damages in connection with the furnishing, performance, or use of this material. No part of this document may be translated to another language without the prior written consent of Wavelength.

LIFE SUPPORT POLICY

This important safety information applies to all Wavelength Electronics, Inc, electrical and electronic products and accessories:

As a general policy, Wavelength Electronics, Inc. does not recommend the use of any of its products in life support applications where the failure or malfunction of the Wavelength product can be reasonably expected to cause failure of the life support device or to significantly affect its safety or effectiveness. Wavelength will not knowingly sell its products for use in such applications unless it receives written assurances satisfactory to Wavelength that the risks of injury or damage have been minimized, the customer assumes all such risks, and there is no product liability for Wavelength. Examples of devices considered to be life support devices are neonatal oxygen analyzers, nerve stimulators (for any use), auto-transfusion devices, blood pumps, defibrillators, arrhythmia detectors and alarms, pacemakers, hemodialysis systems, peritoneal dialysis systems, ventilators of all types, and infusion pumps as well as other devices designated as "critical" by the FDA. The above are representative examples only and are not intended to be conclusive or exclusive of any other life support device.

REVISION HISTORY

REV.	DATE	CHANGE
A	20 Jan 2012	Release
B	3 Sep 2012	Updated pin dimensions
C	April 2014	Added Pin 1 demarcations, extended warranty, added CE Mark, clarified stability with resistive heaters, and updated Ext TEMP SET impedance value



WAVELENGTH
ELECTRONICS

51 Evergreen Drive
Bozeman, Montana 59771

406-587-4910 (tel)
406-587-4911 (fax)

Sales & Tech Support
sales@teamwavelength.com
techsupport@teamwavelength.com

